









1  X6	2  X6	3  ∅8 x30mm X6	4  ∅4x40mm X4	5  M6x25mm X6	6  M6x12mm X6
7  X1	8  M6x22mm X2				



QUELQUES CONSEILS :

1) Bien étudier la notice de montage 2) Repérez les pièces constituant votre meuble 3) Regroupez et contrôlez la quincaillerie 4) Munissez-vous de l'outillage nécessaire 5) Aménagez-vous une zone de montage 6) Procédez au montage - Ne jamais forcer les assemblages. Resserrer les vis après quelque temps d'usage. GARDEZ VOTRE NOTICE DE MONTAGE, si une pièce venait à manquer, elle sera le moyen le plus clair pour communiquer avec votre magasin. 7) Nettoyage avec un chiffon humide. Pour les taches difficiles à supprimer, utiliser une éponge légèrement savonneuse en essuyant aussitôt. Ne pas utiliser de solvants et diluants ni de produits abrasifs.

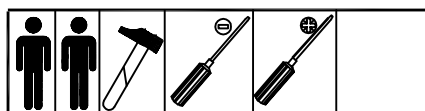
A FEW RECOMMENDATIONS:

1) Read the assembly instructions carefully 2) Identify the elements constituting your piece of furniture 3) Group and check the hardware fittings 4) Get the tools needed 5) Clear a space to work 6) Proceed to assemble - Never force the fittings. Tighten the screws after using for some time. KEEP YOUR ASSEMBLY INSTRUCTIONS, in the event of query, please contact your supplier.

EINIGE EMPFEHLUNGEN :

1) Die Montageanleitung aufmerksam durchlesen 2) Alle Teile markieren, aus denen Ihr Möbel zusammengesetzt ist. 3) Die Beschläge gruppieren und kontrollieren. 4) Das notwendige Werkzeug besorgen. 5) Einen Montagebereich einräumen. 6) Die Montage vornehmen - Niemals Gewalt beim Zusammenfügen anwenden. Nach einer gewissen Benutzungsdauer, die Schrauben anziehen. DIE MONTAGEANLEITUNG SORGFÄLTIG AUFBEWAHREN. Beim Fehlen eines Teiles ist sie das beste Mittel für eine Kommunikation mit ihrem Fachgeschäft.

ALGUNOS CONSEJOS :

1) Estudiar bien las instrucciones de montaje. 2) Ordenar las piezas que constituyen su mueble. 3) Agrupar y controlar la quincaillería. 4) Escoger las herramientas necesarias. 5) Preparar una zona de montaje. 6) Proceder al montaje. No forzar nunca los ensamblajes. Volver a apretar los tornillos después de algún tiempo de utilización. CONSERVAR LAS INSTRUCCIONES DE MONTAJE, si faltaba una pieza, sería el medio más claro para comunicar con su almacén.

ENKELE AANBEVELINGEN :

1) De montage handleiding goed lezen. 2) De elementen die uw meubel samenstellen goed uitzoeken 3) De kleine ijzerwaren verzamelen en controleren. 4) De te gebruiken werktuigen verzamelen. 5) Maak plaats voor de montage. 6) Begin de montage Nooit forceren bij het samenstellen - De schroeven regelmatig aandraaien - Uw montage handleiding zorgvuldig bewaren, mocht er een onderdeel missen dan kan men dankzij de nota het missende deel makkelijk aanduiden.

ALGUNS CONSELHOS :

1) Leia as instruções de montagem com muita atenção. 2) Verifique e ordene as diferentes peças que constituem o seu móvel. 3) Verifique e ordene as diferentes peças de quincailleria. 4) Prepare as ferramentas necessárias. 5) Prepare uma zona de montagem. 6) Proceda à montagem. Não forçar os encaixes/montagem. Voltar a apertar os parafusos após algum tempo de utilização. 7) Limpar com um pano húmido. Para as manchas mais difíceis de eliminar, utilizar uma esponja com água e sabão e secar de imediato. Não utilizar diluentes nem solventes nem produtos abrasivos. CONSERVAR AS INSTRUÇÕES DE MONTAGEM. No caso de faltar uma peça contacte o seu fornecedor.

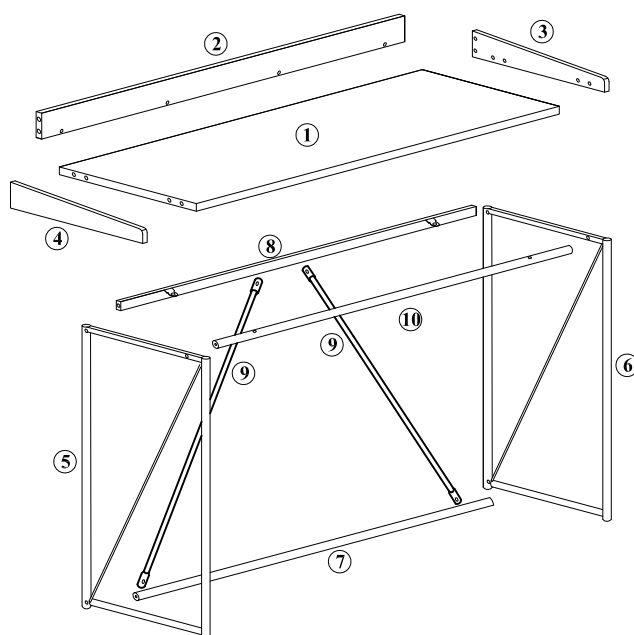

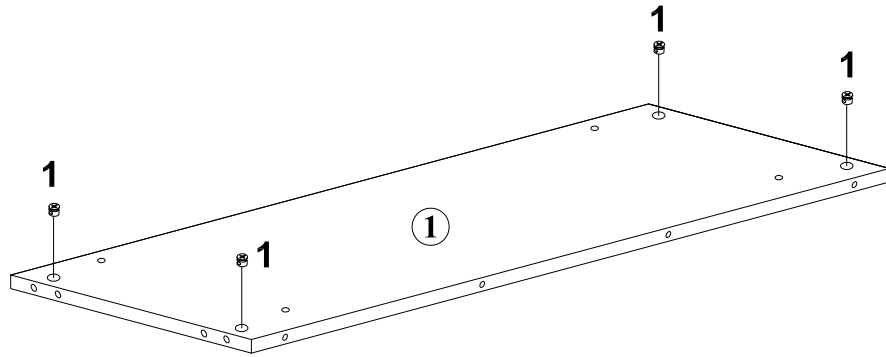
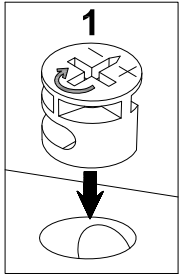

1

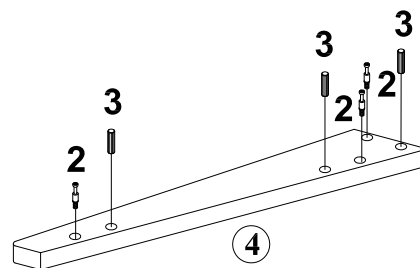
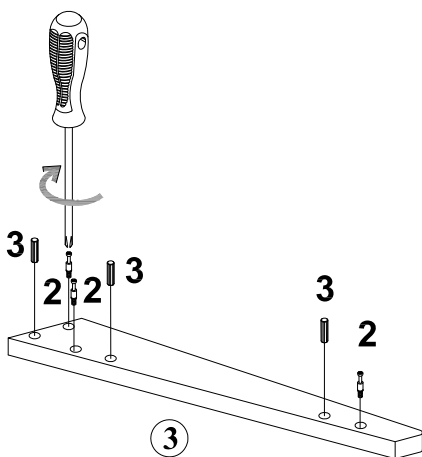
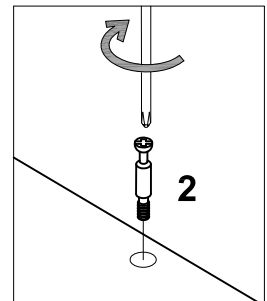

1x4 

2



2x6 
 3x6 

3

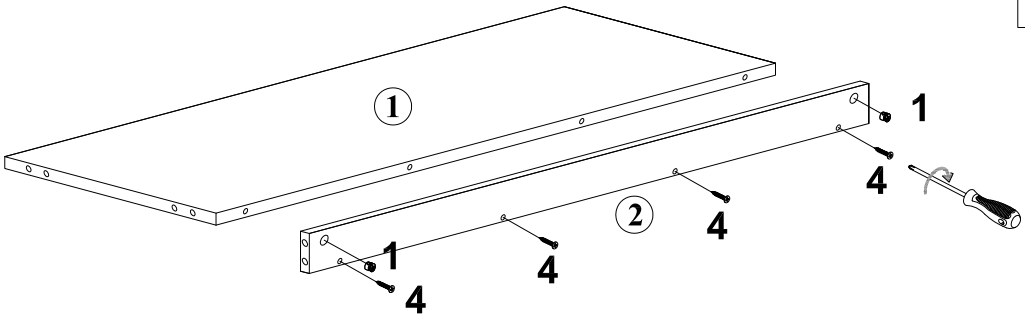
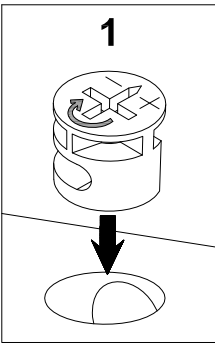

1x2	
4x4	

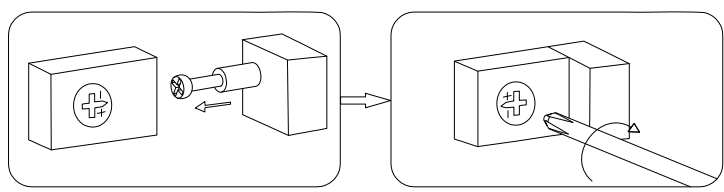
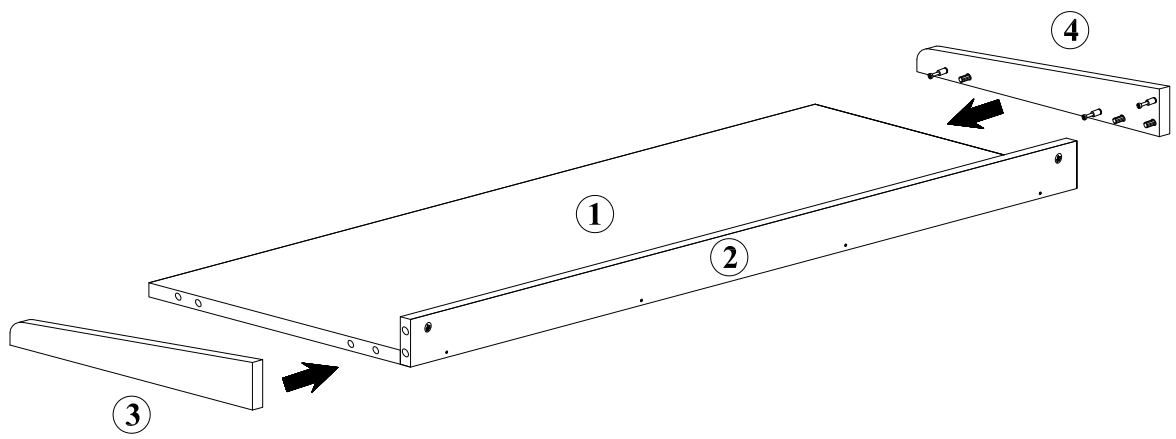

4

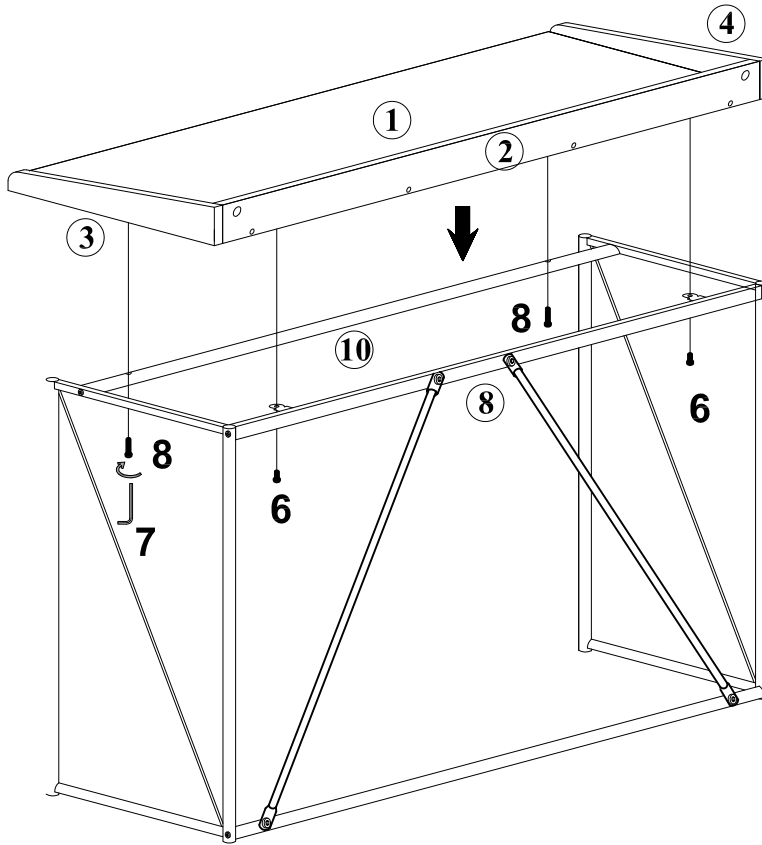

Please hand tighten this with screwdriver!

7



8x2	
6x2	
7x1	

8

